

Drawing ID
EC-S25X / 55EC-S25X

Product Info.	
Finish	Code
Polish	EC-S25M
Satin	EC-S25S
Texture Black	EC-S25B
White	EC-S25W
Brush Brass	EC-S25BB
Polish	55EC-S25M
Satin	55EC-S25S
Texture Black	55EC-S25B

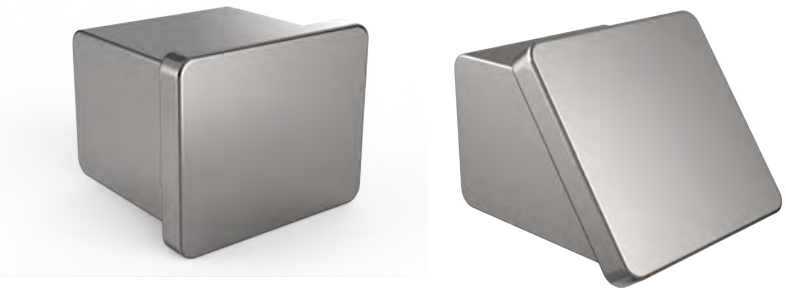
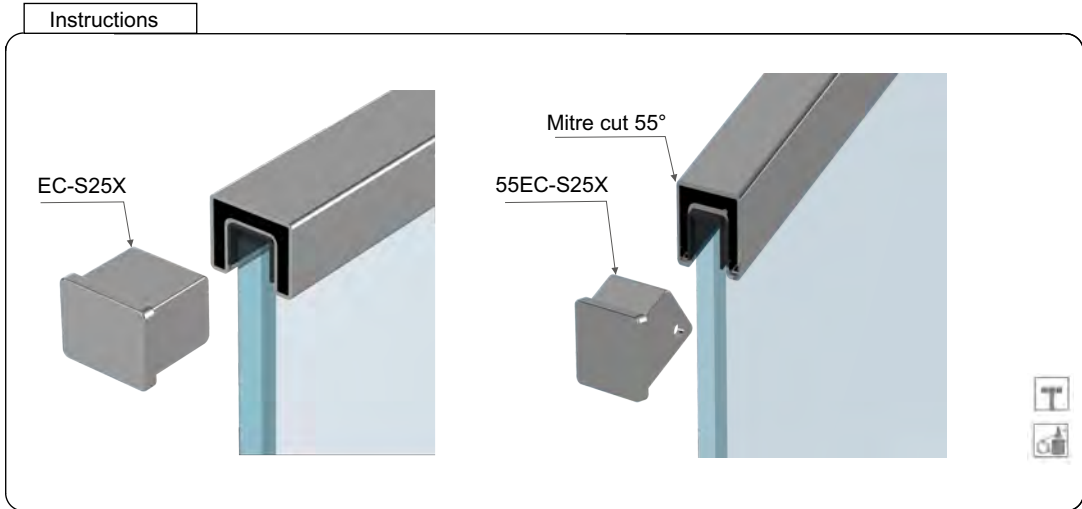
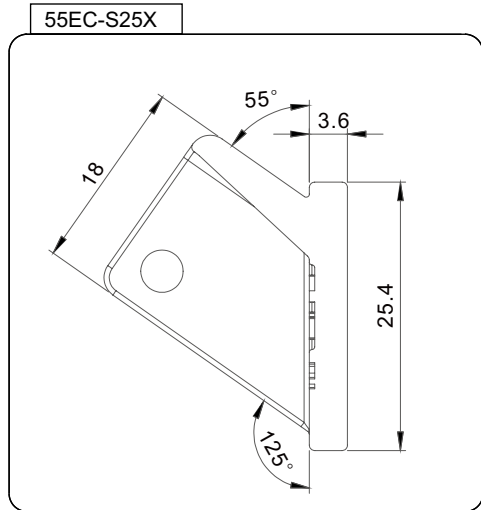
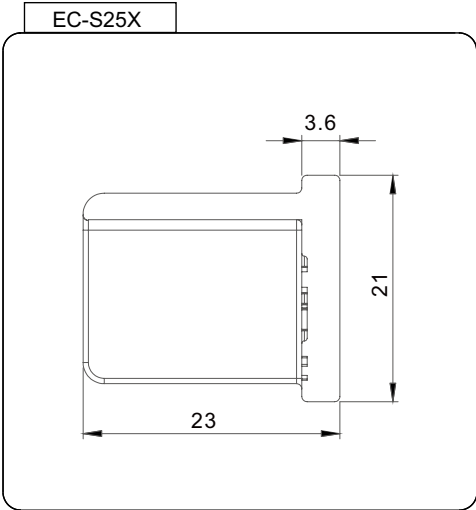

MATERIAL:
2205 Stainless Steel

CATALOGUE AND DESCRIPTION:

- > Railing Systems
- > TR-S25 Series
- > End Cap / 55° End Cap

NOTES:
This drawing and or specification is the property of Silver Stone Hardware Pty Ltd - and must be returned to them on request. Unauthorised use may result in Legal Action. Its contents must not be made public, nor copied, nor used directly or indirectly in any way.

SILVER STONE HARDWARE PTYLID
56-62 Bryant Street, Padstow, NSW 2211
T: (02) 9792 2955 M: 0452 526 680
www.silverstonehardware.com.au
sales@silverstonehardware.com.au